

Jaguar E Type V12 Starter. Part Number 8917094-5AXG

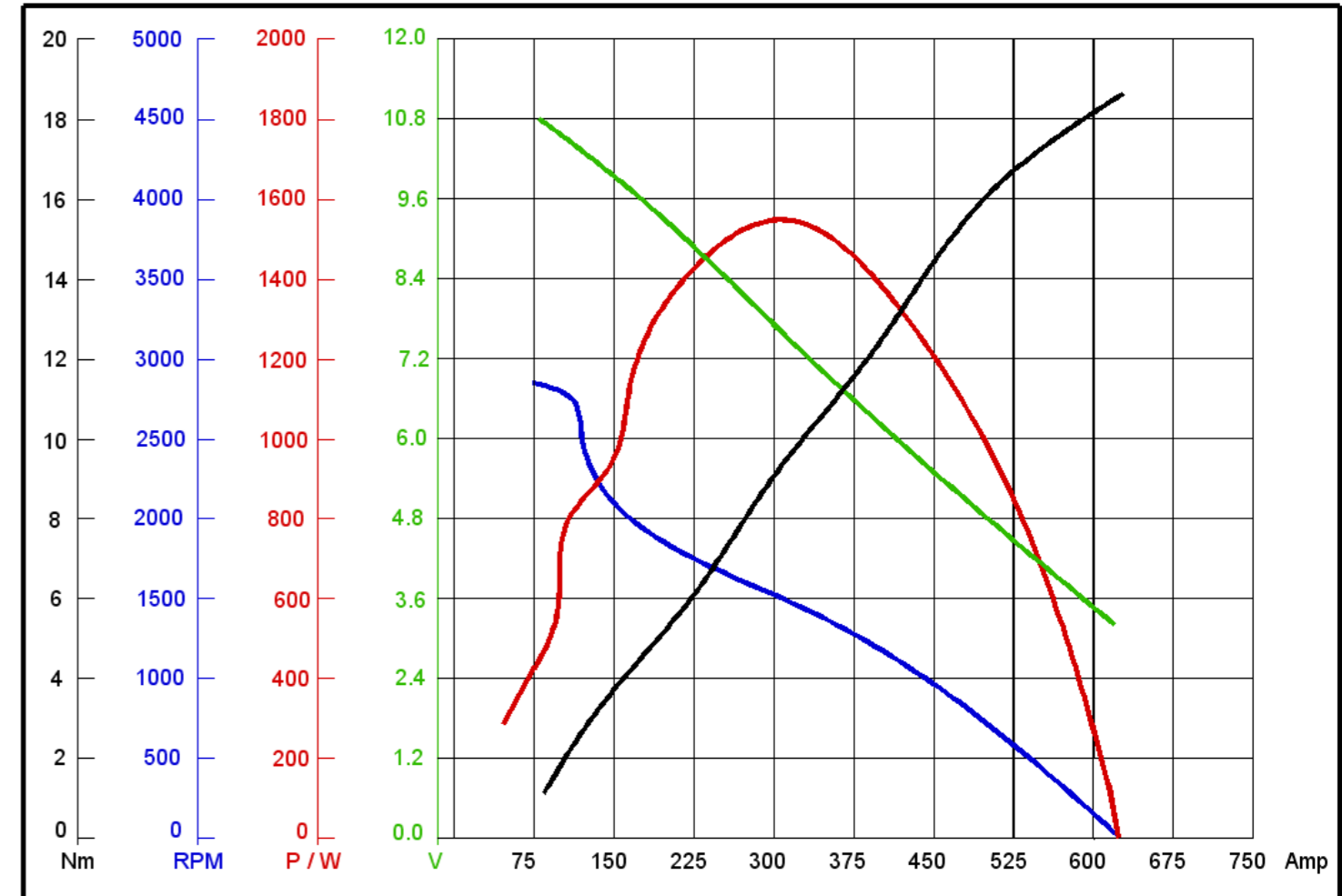
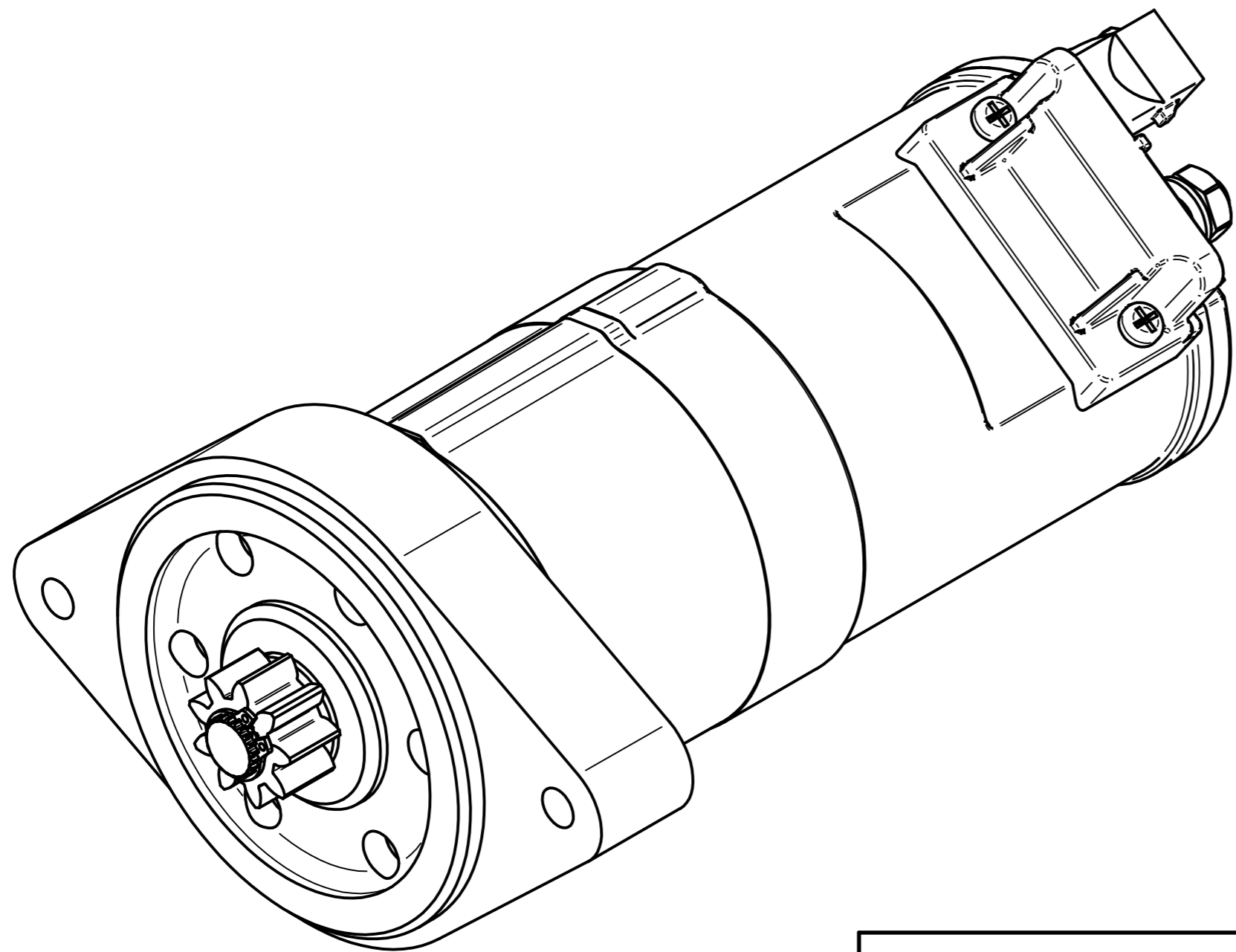
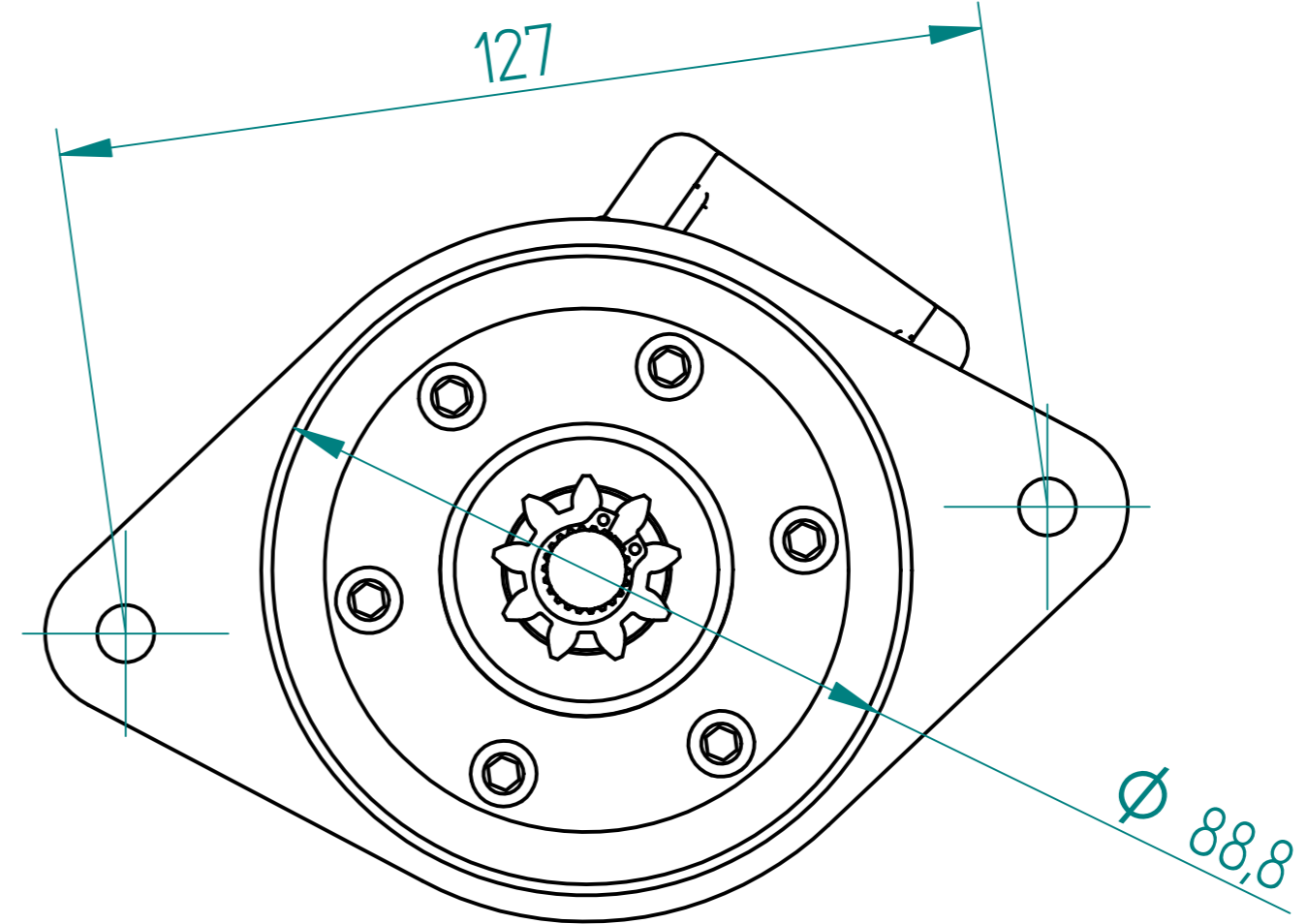
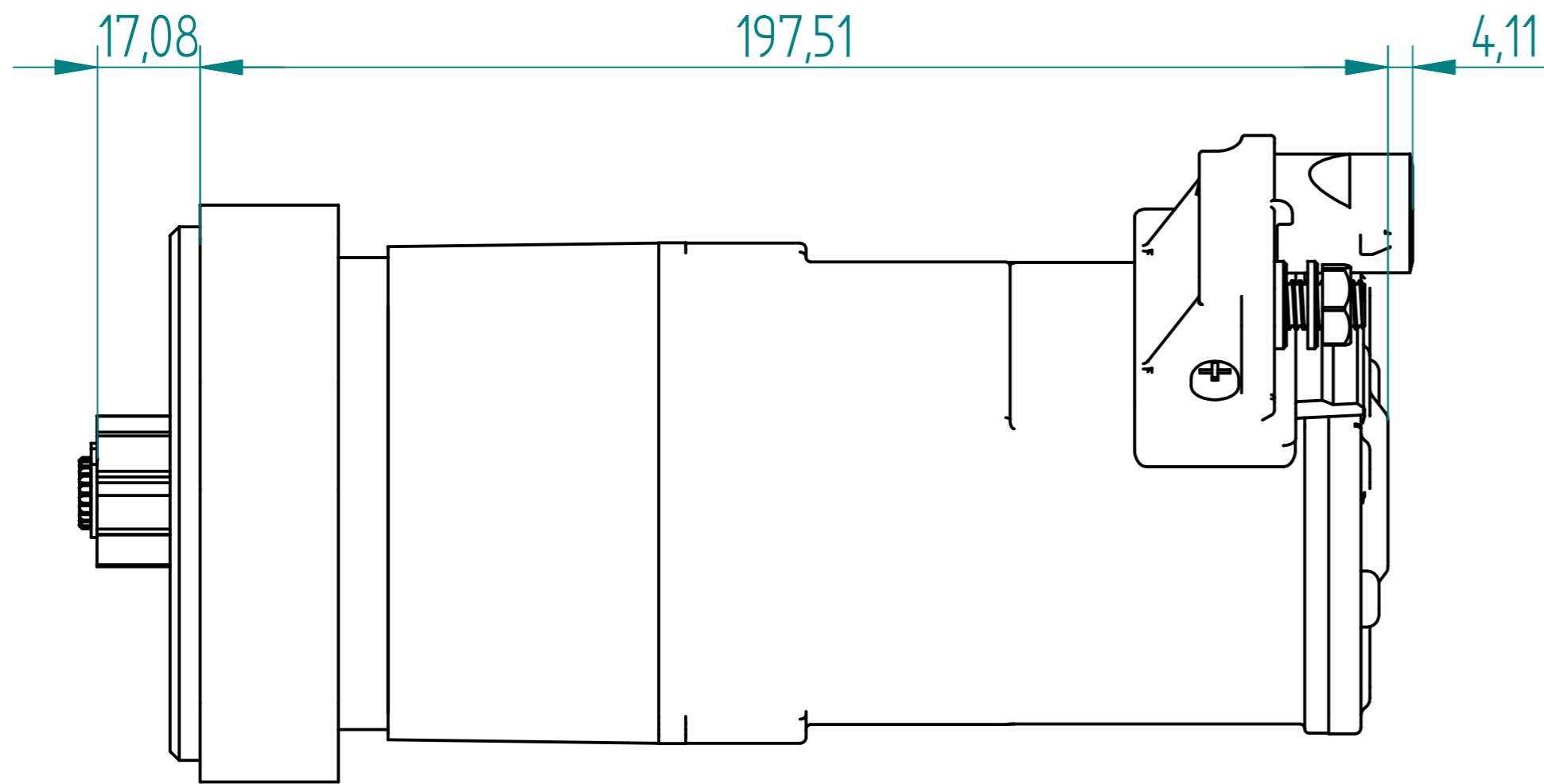

Material		Finish	
Drawn	Name	Date	
Checked	S.W.	26/07/10	
Appro			
Note.			Project: Jaguar E Type V12.
Unless otherwise stated all dimensions in mm.			Item: 8917094-5AXG
			Maximum Torque: 32Nm
Status	Scale 1:1	Sheet 1 of 1	Mass: 2.7kg
© Copyright Brise Ltd. Unit Q3 Northfleet Industrial Estate DA11 9SN All Rights Reserved			

REVISION HISTORY			
REV.	DESCRIPTION	DATE	APPRO