

Fiat X19. Part Number 6411091AXG

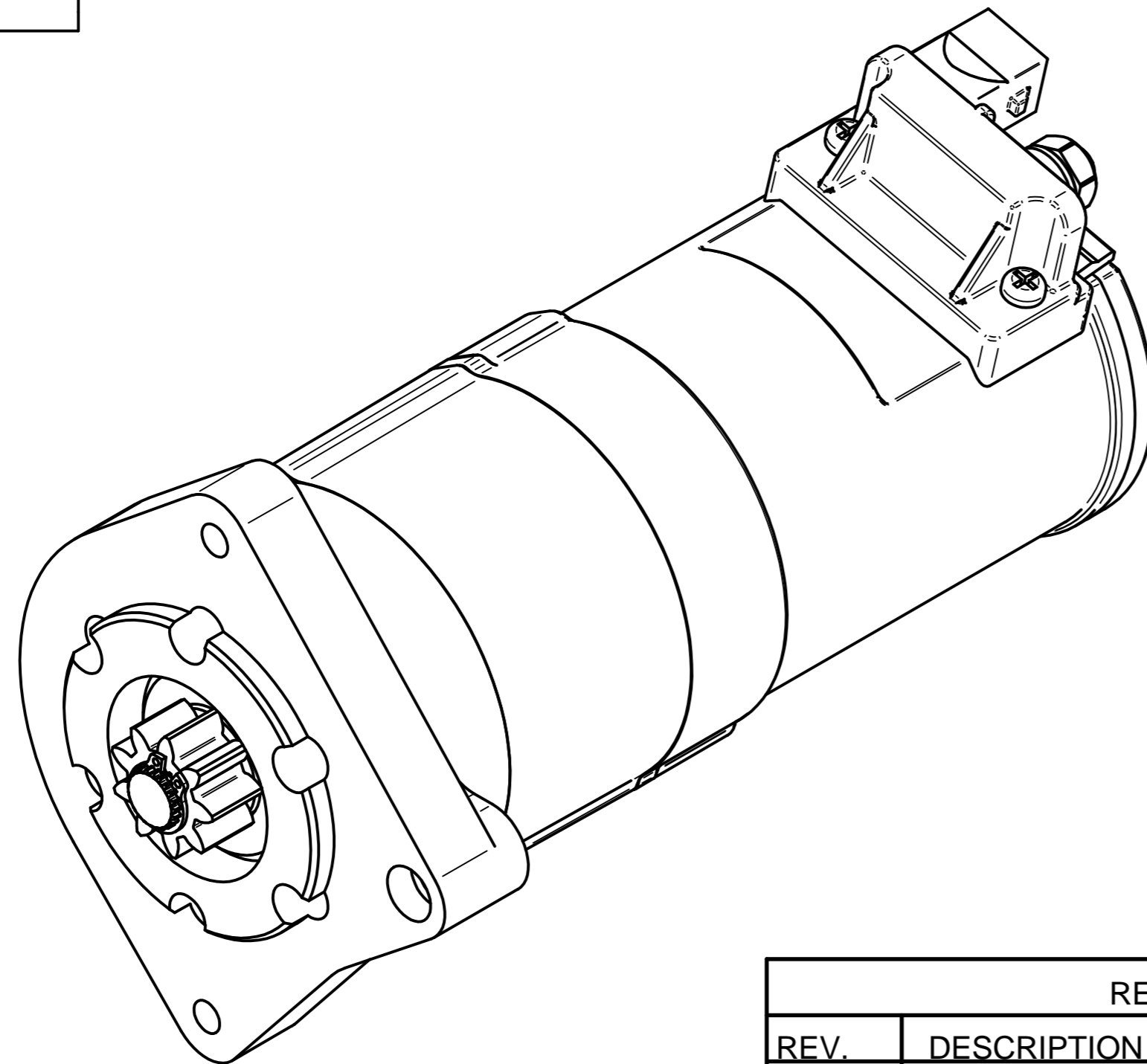
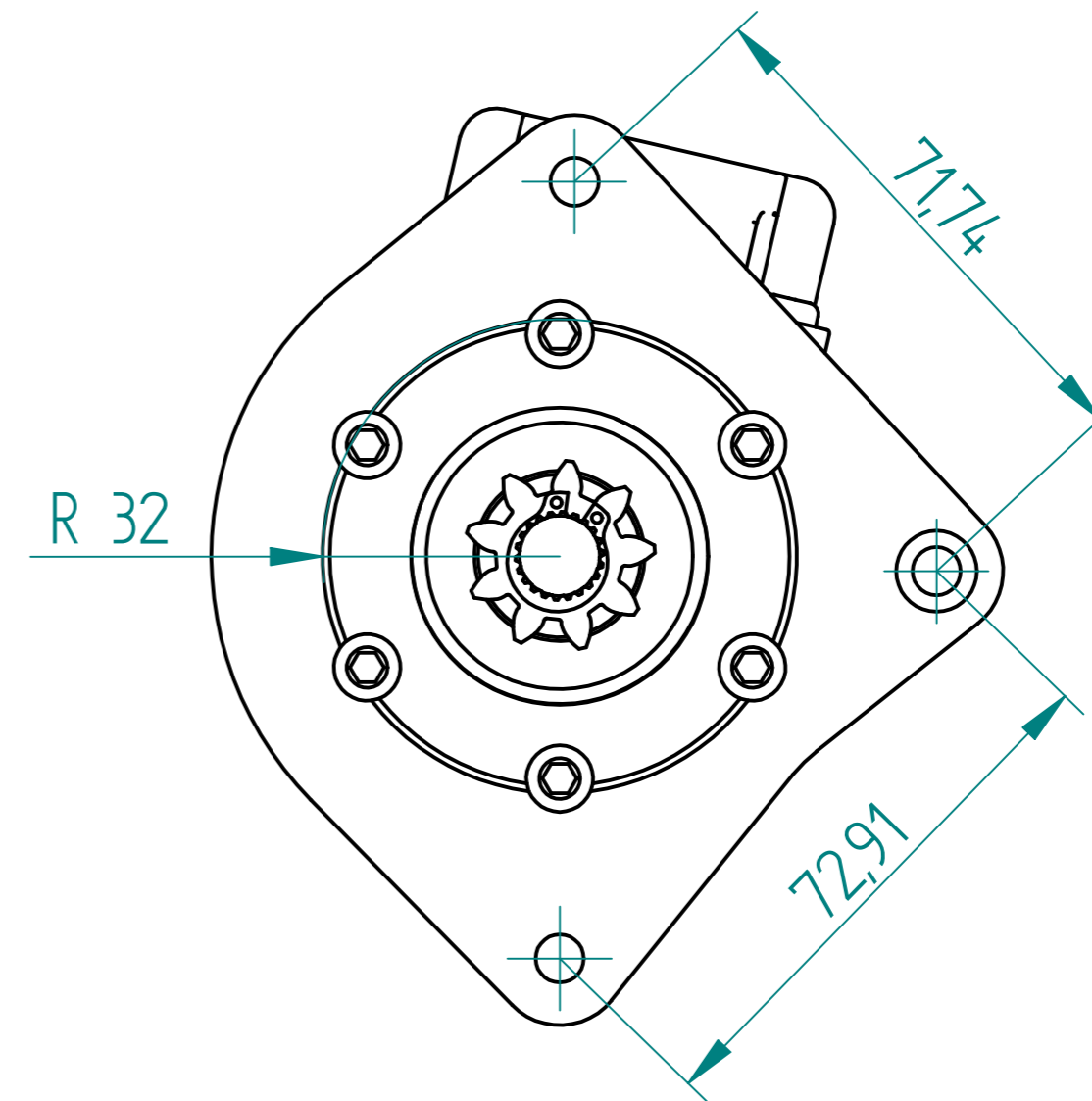
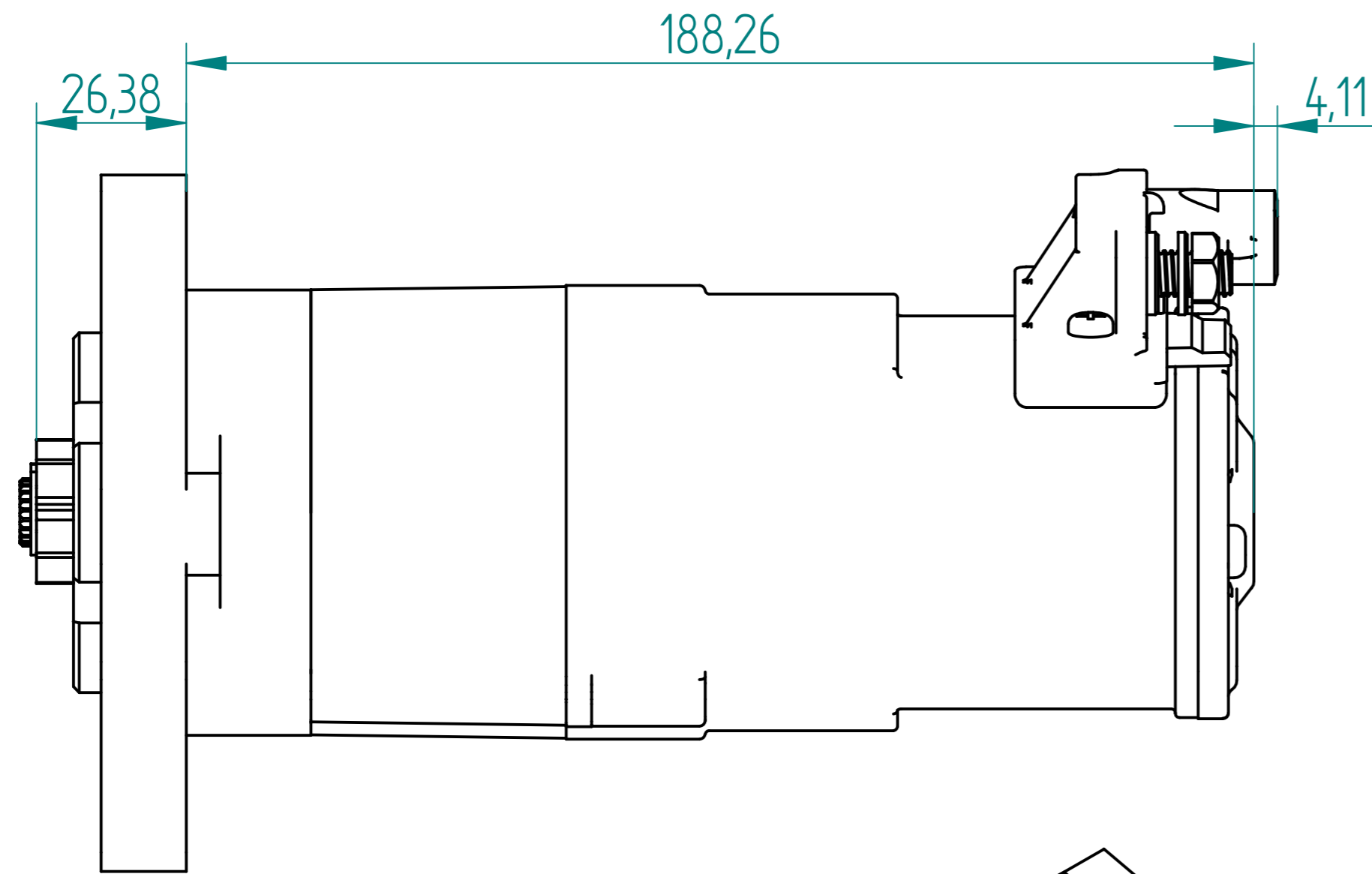

Material			Finish		
Drawn	Name	Date			
Checked	S.W.	21/07/10			
Appro					
Note.					
Unless otherwise stated all dimensions in mm.			Project: Fiat Twin Cam.		
			Item: TC8223113AXG		
			Maximum Torque: 32Nm		
Status			Scale 1:1	Sheet 1 of 1	Mass: 2.7kg
© Copyright Brise Ltd. Unit Q3 Northfleet Industrial Estate DA11 9SN All Rights Reserved					

REVISION HISTORY			
REV.	DESCRIPTION	DATE	APPRO